

## Instruction Manual for the Airspeed MicroSensor V3 Document Version 1.3

Thank you for your purchase! This instruction manual will guide you through the installation and operation of your Airspeed MicroSensor V3 (the MicroSensor). **Please read the entire manual carefully before proceeding.** If, after you read the manual, you have further questions or problems, see the Support page on <http://www.eagletreesystems.com> for additional information, or email us at [support@eagletreesystems.com](mailto:support@eagletreesystems.com). Please visit our support web page for the full color, electronic version of this manual which may be updated if changes were made after printing, or if you want to view the manual on your computer.

### What the MicroSensor Does

The MicroSensor is a precision instrument that uses a Prandtl style pitot-static tube to measure airspeed, just as full sized planes do. Advanced temperature compensation and calibration ensure the best possible accuracy. When used standalone, the MicroSensor displays your maximum speed on the built-in 7 segment LED display. The maximum speed continues to be updated and displayed on the LED, until you turn power off and on the MicroSensor. When power is turned off and on, the maximum speed from the last flight is displayed, and now the MicroSensor is ready to record your next maximum speed (even if it is lower than the previous maximum speed).

Additionally, the MicroSensor can be connected to your eLogger (any version) to provide airspeed data for your entire flight. When connected to the eLogger, airspeed can be displayed and graphed using the eLogger's Windows software.

**IMPORTANT:** It is extremely unlikely that the installation of the MicroSensor will affect your model's radio range or control. But, as always after making an electronics change to your model, it is very important that you range and function test your model once the MicroSensor is installed to ensure that there is no impact on your system.

### Packing List

Your package should include the following: The MicroSensor, a machined brass and aluminum Prandtl style pitot-static tube, the Standalone Cable, approximately 3 feet (1 meter) of small diameter silicon hose, and a printed version of this manual. NOTE: Additional Pitot Tube kits are available for purchase on our website, for use with multiple models.

### Installing the Pitot Tube and MicroSensor in your Model

Using two lengths of the included small diameter silicon tube, the pressure and static connections of the pitot tube connect to the "+" and "-" ports of the MicroSensor, respectively, as shown in Figure 1. It is best to mount the pitot tube in your model first, then determine where you will mount the MicroSensor, and then cut the two lengths of silicon tube so they reach between the two.

Follow these guidelines when mounting the pitot tube:

1. The pickup end of the pitot tube (the silver colored tip) should be pointing toward the direction of the model's travel. While best results will be obtained if the pitot tube is perfectly aligned with the direction of travel in both axes, the "Prandtl" design of the tube will compensate somewhat for higher angles of attack.
2. The static holes on the pitot tube (shown on Figure 1) should extend at least 1/2" (13mm) past the wing's leading edge, or past any other obstructions - the farther out, the better. This is to ensure that the static holes and pitot pickup are in undisturbed air.
3. For prop planes, it's important that the tube be placed so that it is not directly in the plane's prop-wash, which will result in

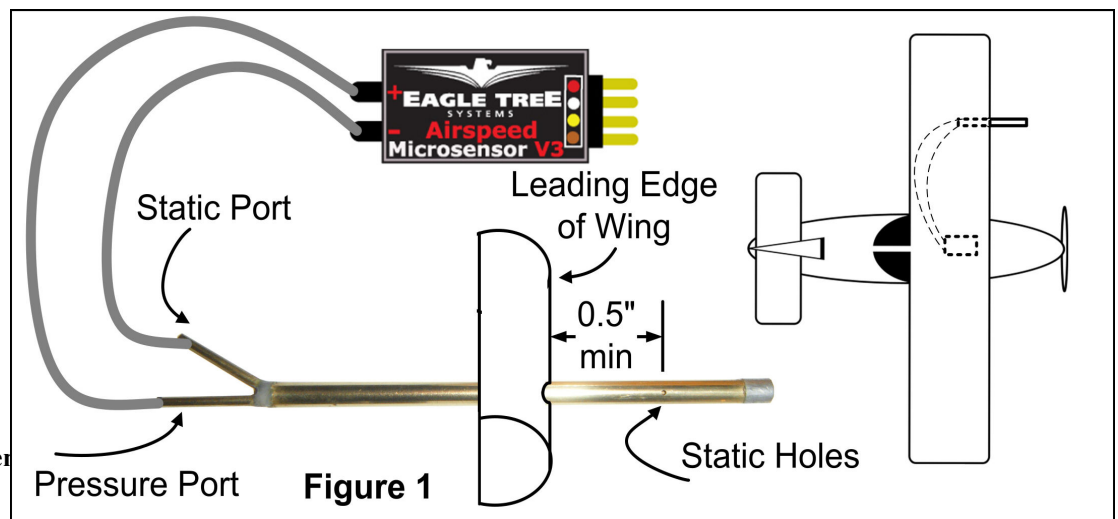

erroneous readings. The best place to install the tube is on the leading edge of the wing several inches out from the fuselage, as shown in Figure 1.

- For jets, gliders, or “pusher” prop planes, the nose cone often provides a perfect mounting location.

After Pitot Tube installation, it is recommended that you glue or otherwise attach the silicon hose to the airframe, to reduce the chance that hose vibration or movement could cause erroneous readings.

The MicroSensor circuit board can be mounted anywhere in the model. If you wish to read the LED without removing the wing, a small rectangular hole can be cut at the mounting location of the circuit board, and the board mounted with tape or Velcro, so that the LED is visible at all times.

## Using the MicroSensor in Standalone Mode

### Powering the MicroSensor in Standalone Mode

For standalone mode (not connected to an eLogger), connect the Standalone Cable to the gold pins of the MicroSensor, as shown in Figure 2. Note that the RED wire of the standalone cable corresponds with the red dot on the label.

The JR/Universal servo end of the Standalone Cable connects to a spare Receiver channel or small battery. Note that the voltage must be between 3V and 16V. **Do not exceed 16V!**

**IMPORTANT: Ensure that you connect the Standalone Cable with the correct polarity, or the MicroSensor could be damaged, voiding the warranty!**

**Note that in Standalone Mode, the 4 wire cable built into the MicroSensor must NOT be connected to anything!**

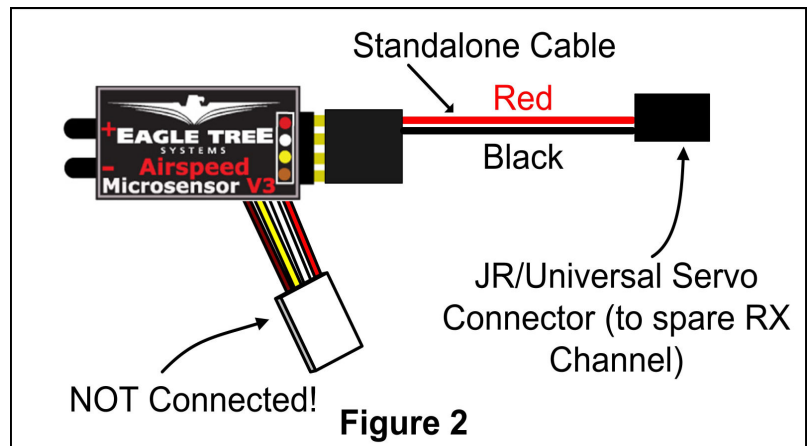

### Configuring Metric vs English Units in Standalone Mode

When powered on, the LED readout will briefly display “0” if the unit is configured for English (MPH), or will display a “1” if configured for metric (KPH). The factory default configuration is MPH.

To switch between English and metric units, connect the Standalone Cable as described above, but don’t power the MicroSensor. Then, connect a small piece of wire between the unconnected pins of the Standalone Cable’s 4 pin connector, corresponding to the brown and yellow dots on the label, as shown in Figure 3. This creates a jumper between the brown and yellow labeled pins.

Then, power the MicroSensor via the Standalone Cable. A “0” will then flash a few times to indicate that English units are configured, or a “1” will flash if Metric units are configured. If the wrong units are configured, just disconnect the power from the MicroSensor and reconnect it.

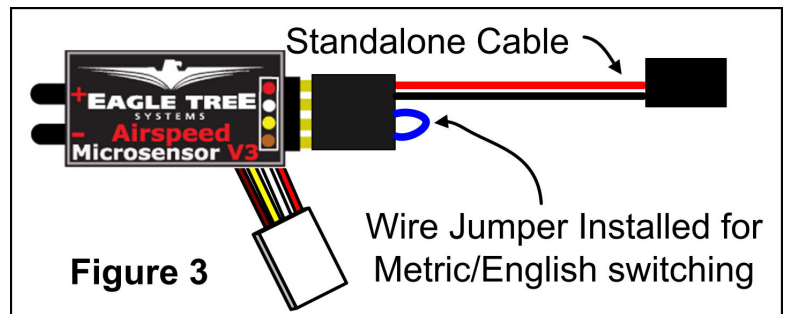

Once the desired units are configured, disconnect from power and remove the wire jumper. Then, when reconnected to power, the desired units should be displayed briefly (“0” or “1”).

### Reading Airspeed in Standalone Mode

When the MicroSensor is powered on, after the Units setting is displayed (“0” or “1”), the highest speed attained during your last flight is repeatedly displayed, one digit at a time, on the LED. For example, if the highest speed attained was 120MPH, “1 – 2 – 0” will flash repeatedly on the LED, with a pause (blank LED) after the speed is completely displayed, but before it is displayed again.

To reset the max trigger, just turn power off and on to the MicroSensor. Then, after landing from your next flight, the highest speed attained during that flight is displayed automatically, overwriting the highest speed from your prior flight. **Note that a speed of at least 9 MPH (15 KPH) must be attained before a new highest speed is displayed.**

The highest speed of your last flight is automatically saved, so that when you turn the unit back on, that speed is displayed.

For example, if you fly and reach a max speed of 100 MPH, when you land “1 – 0 – 0” will be displayed. Then, when you turn power off and on, “1 – 0 – 0” will again be displayed. If you then fly again and reach a speed of 50 MPH, “5 – 0” will be displayed when you land.

## Using the MicroSensor with your eLogger

### Windows Application and Firmware Update

To use the MicroSensor, you must update to **Eagle Tree Windows Application version 6.77** or higher. To update, download the latest application from the support page of our website, located at <http://eagletreesystems.com/Support/apps.htm>. After downloading and installing the Application, the firmware of your MicroPower eLogger will need to be updated. To upgrade your firmware, just choose “Tools, Firmware Control” and click the Update button.

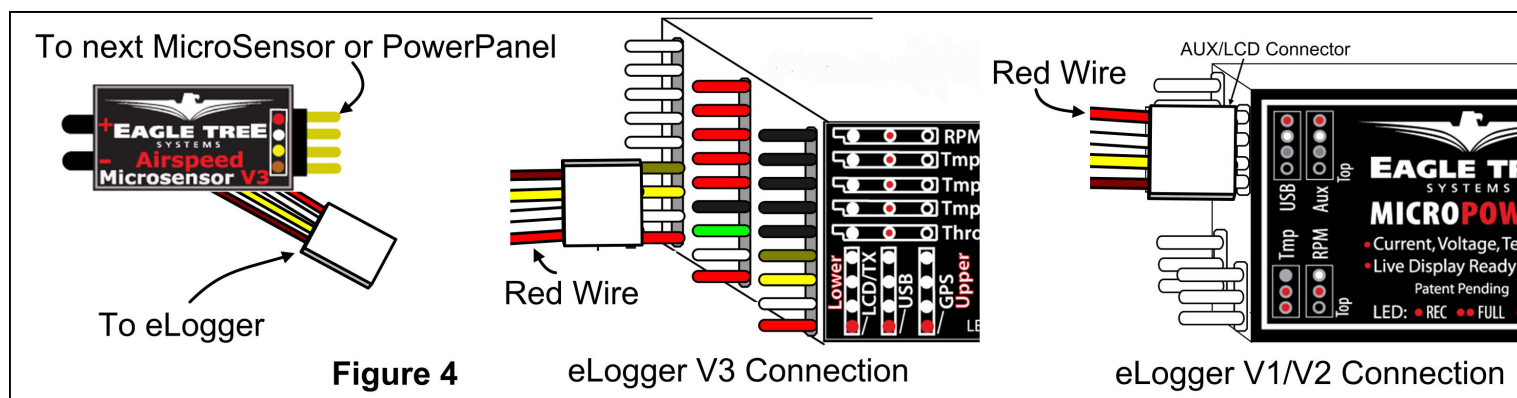

### Connecting the MicroSensor to the eLogger V3

The MicroSensor plugs into the “LCD/TX” port of your eLogger V3, as shown in Figure 4. If you have a PowerPanel or other MicroSensors, those can “daisy chain” connect to the pins on the other side of your MicroSensor, with the polarity as indicated on the MicroSensor label. **NOTE: The Standalone Cable must not be used when connected to the eLogger!**

### Connecting the MicroSensor to the eLogger V1/V2

The MicroSensor plugs into the “Aux” or “LCD” port of your eLogger V1/V2, as shown in Figure 4. If you have a PowerPanel or other MicroSensors, those can “daisy chain” connect to the pins on the other side of your MicroSensor, with the polarity as indicated on the MicroSensor label. **NOTE: The Standalone Cable must not be used when connected to the eLogger!**

### Configuring the MicroSensor with the Windows Application

If you have not already done so, set up the Recorder software as described in your instruction manual. Then, choose one or more of the MicroSensor options below:

#### Logging Airspeed

To log airspeed, just click “Hardware, Choose Parameters to Log in the Recorder” and check the “Airspeed” box.

#### Displaying Airspeed in the Windows Application

To display the Airspeed Gauge and/or Numeric Airspeed Display, click “Software, Choose Instruments to Display on the PC Screen” and check the “Airspeed Indicator Gauge,” and/or “Numeric Speed” boxes.

#### Graphing Airspeed

To graph airspeed, click “Chart, 2D Chart,” select either the Left Y Axis or Right Y Axis, and select “Speed” for graphing.

#### Displaying Airspeed on the PowerPanel

Select “Hardware, Configure PowerPanel Display”, and choose “Speed” for PowerPanel display.

## Troubleshooting

Below is a list of problems that may be encountered, and steps to remedy them. If your particular issue is not addressed by the below, see the Support page on <http://eagletreesystems.com> or email [support@eagletreesystems.com](mailto:support@eagletreesystems.com). Include a full description of your problem, your PC configuration, your Eagle Tree hardware and software versions, and any other relevant information.

**Issue:** Airspeed doesn't vary in my recordings

**Solutions:**

- Ensure that the MicroSensor is connected correctly to the MicroPower
- Ensure that you are logging airspeed, under "Tools, Choose Parameters to Log in the Recorder"
- Ensure that the Pitot Tube is connected

**Issue:** My plane shows an airspeed variation during warm-up on the ground as I rev the throttle.

**Solution:** This problem can occur when the Pitot Tube's opening is being hit by prop-wash. The solution is to move the tube farther away from propeller airflow. Note that slight variations in speed is normal when stationary.

### Specifications (Approx)

- Measures airspeed from 2 MPH to 350 MPH (3KPH to 563KPH), with 1 MPH (1 KPH) Resolution
- Power input (Standalone Mode) – 3V to 16V
- Circuit Board: Weight 4 grams (0.15 oz), dimensions 28 mm x 16 mm x 10 mm (1.1" x 0.62" x 0.4")
- Pitot Tube: Weight 3 grams (0.1 oz), length 80mm (3.2"), diameter 4 mm (0.16")
- Precalibrated – no user calibration required
- Advanced Temperature Compensation
- Metric or English units

### Limited Warranty

Eagle Tree Systems, LLC, warrants the MicroSensor to be free from defects in materials and workmanship for a period of one (1) year from the date of original purchase. This warranty is nontransferable. If your unit requires warranty service during this period, we will replace or repair it at our option. Shipping cost to us is your responsibility. To obtain warranty service, email [support@eagletreesystems.com](mailto:support@eagletreesystems.com) for further instructions.

This limited warranty does not cover:

- The Software. See the Software license agreement for more information on Software restrictions.
- Problems that result from:
  - External causes such as accident, abuse, misuse, or problems with electrical power
  - Servicing not authorized by us
  - Usage that is not in accordance with product instructions
  - Failure to follow the product instructions

THIS WARRANTY GIVES YOU SPECIFIC LEGAL RIGHTS, AND YOU MAY ALSO HAVE OTHER RIGHTS WHICH VARY FROM STATE TO STATE (OR JURISDICTION TO JURISDICTION). OUR RESPONSIBILITY FOR MALFUNCTIONS AND DEFECTS IN HARDWARE IS LIMITED TO REPAIR AND REPLACEMENT AS SET FORTH IN THIS WARRANTY STATEMENT. ALL EXPRESS AND IMPLIED WARRANTIES FOR THE PRODUCT, INCLUDING, BUT NOT LIMITED TO, ANY IMPLIED WARRANTIES AND CONDITIONS OF MERCHANTABILITY AND FITNESS FOR A PARTICULAR PURPOSE, ARE LIMITED IN TIME TO THE TERM OF THE LIMITED WARRANTY PERIOD AS DESCRIBED ABOVE. NO WARRANTIES, WHETHER EXPRESS OR IMPLIED, WILL APPLY AFTER THE LIMITED WARRANTY PERIOD HAS EXPIRED. SOME STATES DO NOT ALLOW LIMITATIONS ON HOW LONG AN IMPLIED WARRANTY LASTS, SO THIS LIMITATION MAY NOT APPLY TO YOU.

WE DO NOT ACCEPT LIABILITY BEYOND THE REMEDIES PROVIDED FOR IN THIS LIMITED WARRANTY OR FOR CONSEQUENTIAL OR INCIDENTAL DAMAGES, INCLUDING, WITHOUT LIMITATION, ANY LIABILITY FOR THIRD-PARTY CLAIMS AGAINST YOU FOR DAMAGES, FOR PRODUCTS NOT BEING AVAILABLE FOR USE, OR FOR LOST DATA OR LOST SOFTWARE. OUR LIABILITY WILL BE NO MORE THAN THE AMOUNT YOU PAID FOR THE PRODUCT THAT IS THE SUBJECT OF A CLAIM. THIS IS THE MAXIMUM AMOUNT FOR WHICH WE ARE RESPONSIBLE. SOME STATES DO NOT ALLOW THE EXCLUSION OR LIMITATION OF INCIDENTAL OR CONSEQUENTIAL DAMAGES, SO THE ABOVE LIMITATION OR EXCLUSION MAY NOT APPLY TO YOU.