



Instruction Manual for the Brushless Motor RPM Sensor Document Version 1.7

Thank you for your purchase! This instruction manual will guide you through the installation and operation of your Brushless Motor RPM Sensor (the Sensor). **Please read the entire manual carefully before proceeding.** If, after you read the manual, you have further questions or problems, see the Support page on <http://www.eagletreesystems.com> for additional information, or email us at support@eagletreesystems.com.

IMPORTANT: It is unlikely that the installation of the Sensor will affect your model’s radio range or control. But, as always after making an electronics change to your model, it is very important that you range and function test your model once the Sensor is installed to ensure that there is no impact on your system. Make sure that your “antenna down” operating range is within the manufacturer’s specifications. See your Radio owner’s manual for the correct procedure for your equipment. **DO NOT OPERATE IF YOUR MODEL DOESN’T PASS THE ANTENNA DOWN RANGE CHECK.**

Packing List

Your package should include the following: The Brushless Motor RPM Sensor, and a printed version of this manual. Please check your packaging for printed addenda to this manual which may be included if changes were made after printing.

How the Sensor Works

The Brushless Motor Sensor works with your Data Recorder/MicroPower to measure RPM via pulses from any two of the wires leading from your Electronic Speed Controller (ESC) to your motor. The sensor works with all known brushless motors. If you have a brushed motor, the sensor will not work. Brushed motor RPM can be measured with our Magnetic or Optical RPM sensors.

Supported Products

The Sensor works with the following Eagle Tree Products: MicroPower (all versions), and all Seagull Flight Systems and Data Recorder V2 products with firmware version “4.XX”.

Steps to Follow

Installation and use of your Sensor should be quite easy and enjoyable if you follow these few steps:

1. Read through the manual to understand the warnings, determine the installation and setup sequence, etc.
2. Upgrade the Windows Application and Firmware for your Recorder as described in the “Windows Application and Firmware Update” section below.
3. Complete the installation as described below.

Windows Application and Firmware Update

To use the Sensor, you must update to Windows Application version 4.37 or higher. To update, download the latest application from the support page of our website. After downloading and installing the Application, the firmware of your Recorder may need to be updated. **Firmware version 4.64 or greater** is required for the Sensor to work correctly. To upgrade your firmware, choose “Tools, Firmware Control” and click the Update button.

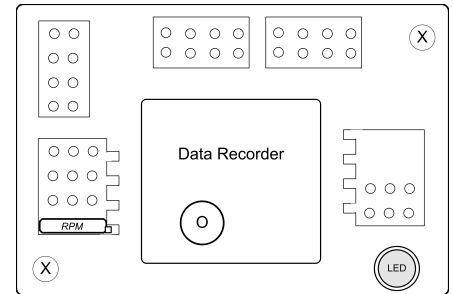

Figure 1

Connecting the Brushless Motor Sensor the Pro, Flight, Car or Boat Data Recorder

The Sensor plugs into your Data Recorder as shown in Figure 1. Make sure that you connect it in the correct location on the recorder, and with the correct polarity (the plug is polarized).

NOTE: Make sure the power supply to the Recorder (from the Y cables or separate battery pack) is less than about 5.6V when using the Brushless RPM Sensor, for the most reliable operation.

The Brushless sensor can also be used as a secondary RPM sensor with your Recorder. Up to 4 RPMs can be measured in this way (with the Pro Recorder). To use the Brushless sensor as a Secondary sensor, please see your Seagull or Recorder instruction manual for instructions on modifying it.

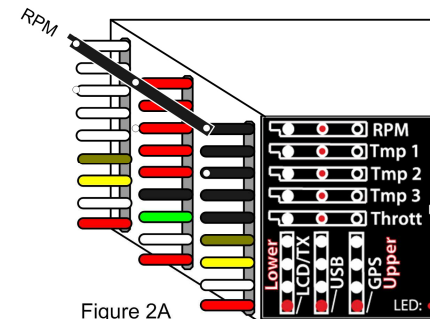

Figure 2A

Connecting the Sensor to the eLogger V3

The Sensor plugs into the RPM port of the eLogger V3, as shown in Figure 2A.

Connecting the Sensor to the eLogger V1 or V2

The Sensor plugs into the RPM port of the MicroPower, as shown in Figure 2.

Connecting the Sensor to your Power System

WARNING: The wires of the Sensor are designed to carry only the tiny currents required for the Sensor to measure RPM. The wires must never be connected in a way where large current could flow through them, or in a way where they could become damaged and short with other conductors.

There are two unconnected wires extending from the Sensor, labeled “To Motor 1” and “To Motor 2” (See Figure 3). These wires need to be electrically connected to any 2 of the 3 wires leading from your ESC to your motor. The end of these wires can be soldered, clipped or otherwise electrically connected to one of the motor wires. If you use “bullet” type plugs between your motor and ESC, it is very easy to connect the RPM sensor wires, by just stripping off a short piece of the insulation, and connecting the bullet plug with the stripped RPM wire inside it.

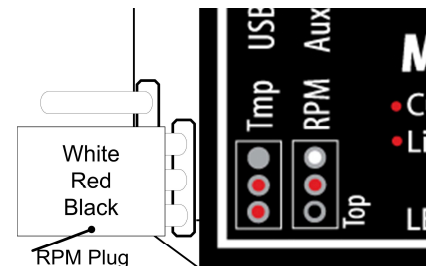

Figure 2

For convenience, if you plan on frequently moving the Sensor between motors, a small plug could be attached to one of the motor leads and the mating plug attached to the “To Motor 1” and “To Motor 2” wires. Or, for more portability, if it can be done safely, a short straight pin could be connected to the Sensor “To Motor 1” and “To Motor 2” wire, and the pin could be used to pierce the insulation of one of your motor wires, thus forming an electrical connection.

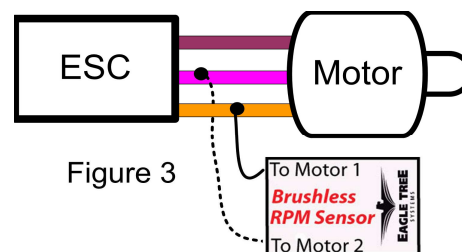

Figure 3

Configuring and Calibrating the Sensor with the Windows Application

If you have not already done so, install your Data Recorder or MicroPower in your model and set up the Recorder software as described in your instruction manual.

To calibrate the RPM sensor, you need to know the number of “poles” your brushless motor has. This information is normally supplied by the motor manufacturer. The term “poles” refers to the number of magnets in the motor (NOT the number of stator teeth, “legs,” or “hammerheads.”) For example, if you have an outrunner with 10 teeth on the stator and 14 magnets in the flux ring, the motor has 14 poles. Note that most (but not all) in-runner motors are two pole motors.

If you are uncertain about the number of poles, or want to verify you calculated correctly, a hand-held tachometer can be used to compare the RPM value displayed real-time by your recorder, in a bench test (assuming it is safe for you to do this). Real-time display is available in Recorder USB Live Mode, on the MicroPower PowerPanel, or with the Seagull Wireless Dashboard. If the value displayed is incorrect, you can change the poles setting to adjust the displayed RPM value. For example, if your handheld tachometer reads 4000 RPM, and your Eagle Tree data shows the maximum RPM of 8000, you would need to double the number of poles to “2.”

For Pro, Flight, Boat or MicroPower users, click on “Tools, Calibrate Motor RPM”, select the “Brushless Motor RPM Sensor” option, and enter the number of Poles and the gear ratio. For Car Recorder users, Choose “Tools, Calibrate Speed from RPM” and follow the above procedure.

Troubleshooting

Below is a list of problems that may be encountered, and steps to remedy them. If your particular issue is not addressed by the below, see the Support page on <http://eagletreesystems.com> or email support@eagletreesystems.com. Include a full description of your problem, your machine configuration, brands/models of receivers, transmitters and servos, Windows Application and Recorder firmware version if possible, and any other relevant details.

Issue: RPM is not working correctly

Solutions:

- In the Windows Application, make sure that the “Brushless Motor RPM Sensor” option is selected in “Tools, Calibrate Motor RPM” or “Tools, Calibrate Speed from RPM”, and make sure your number of poles and gear ratio are set correctly.
- For recording RPM, make sure that when you click “Tools, Choose What to Log” in the Windows Application, you have checked RPM.
- If you are using the sensor with a Data Recorder, make sure the power supply to the Recorder (from the Y cables or separate battery pack) is less than about 5.6V.

Limited Warranty

Eagle Tree Systems, LLC, warrants the Brushless Motor RPM Sensor to be free from defects in materials and workmanship for a period of one (1) year from the date of original purchase. This warranty is nontransferable. If your unit requires warranty service during this period, we will replace or repair it at our option. Shipping cost to us is your responsibility. To obtain warranty service, email support@eagletreesystems.com for further instructions.

This limited warranty does not cover:

- The Software. See the Software license agreement for more information on Software restrictions.
- Problems that result from:
 - External causes such as accident, abuse, misuse, or problems with electrical power
 - Servicing not authorized by us
 - Usage that is not in accordance with product instructions
 - Failure to follow the product instructions

THIS WARRANTY GIVES YOU SPECIFIC LEGAL RIGHTS, AND YOU MAY ALSO HAVE OTHER RIGHTS WHICH VARY FROM STATE TO STATE (OR JURISDICTION TO JURISDICTION). OUR RESPONSIBILITY FOR MALFUNCTIONS AND DEFECTS IN HARDWARE IS LIMITED TO REPAIR AND REPLACEMENT AS SET FORTH IN THIS WARRANTY STATEMENT. ALL EXPRESS AND IMPLIED WARRANTIES FOR THE PRODUCT, INCLUDING, BUT NOT LIMITED TO, ANY IMPLIED WARRANTIES AND CONDITIONS OF MERCHANTABILITY AND FITNESS FOR A PARTICULAR PURPOSE, ARE LIMITED IN TIME TO THE TERM OF THE LIMITED WARRANTY PERIOD AS DESCRIBED ABOVE. NO WARRANTIES, WHETHER EXPRESS OR IMPLIED, WILL APPLY AFTER THE LIMITED WARRANTY PERIOD HAS EXPIRED. SOME STATES DO NOT ALLOW LIMITATIONS ON HOW LONG AN IMPLIED WARRANTY LASTS, SO THIS LIMITATION MAY NOT APPLY TO YOU.

WE DO NOT ACCEPT LIABILITY BEYOND THE REMEDIES PROVIDED FOR IN THIS LIMITED WARRANTY OR FOR CONSEQUENTIAL OR INCIDENTAL DAMAGES, INCLUDING, WITHOUT LIMITATION, ANY LIABILITY FOR THIRD-PARTY CLAIMS AGAINST YOU FOR DAMAGES, FOR PRODUCTS NOT BEING AVAILABLE FOR USE, OR FOR LOST DATA OR LOST SOFTWARE. OUR LIABILITY WILL BE NO MORE THAN THE AMOUNT YOU PAID FOR THE PRODUCT THAT IS THE SUBJECT OF A CLAIM. THIS IS THE MAXIMUM AMOUNT FOR WHICH WE ARE RESPONSIBLE. SOME STATES DO NOT ALLOW THE EXCLUSION OR LIMITATION OF INCIDENTAL OR CONSEQUENTIAL DAMAGES, SO THE ABOVE LIMITATION OR EXCLUSION MAY NOT APPLY TO YOU.