



Instruction Manual for the eLogger V3

Patent Pending

Document Version 1.5, Model # MPRV3-CONN-100, MPRV3-LEADS-100, and MPRV3-LEADS-150

Thank you for your purchase! This instruction manual will guide you through the installation and operation of your eLogger.

Please read the entire manual carefully before proceeding. If, after you read the manual (including the Troubleshooting sections!) you have further questions or problems, please visit our web support page for additional support options, at <http://www.eagletreesystems.com/Support/support.html>. Note that the latest version of this manual is available in PDF form from the Support page of our website.

Please also fill out the registration form at the end of this manual if you did not purchase your eLogger directly from Eagle Tree Systems, so we can send you important update information.

Key Features

Here are a few of the features of the eLogger:

- Logs peak current to +/- 100 amps (150 amps with MPRV3-LEADS-150) and voltage from about 5 volts to 70 volts
- Current is measured with a true Hall Effects Sensor - NOT a resistance shunt like other units on the market!
- Great for bench monitoring of battery charging also!
- Supports the PowerPanel LCD Display
- Accepts optional inexpensive sensors for three Temperatures, RPM (brushless, magnetic or optical), Airspeed, Altitude, GPS, Servo Current, Throttle Movement, and more
- Adjustable logging rate (1-10 samples/second) and lossless data compression for long log times
- 4 times the logging space of the eLogger V2, and all data is logged to permanent memory, which retains the data even when the power is removed
- Software computes Wattage, mAH, etc. for complete e-flight data.
- Fully Compatible with Windows Vista, 98SE, ME, Win2K and XP™
- Integrated USB with included cable (NOT a USB to serial port cable like other loggers)
- Weighs about 0.7 oz (20 grams). Versions with Wire Leads weighs slightly more.
- Supports USB Live Mode, which lets you see what's happening in the model LIVE on the bench, on your PC
- Comes with our state of the art Windows virtual playback display and graphing
- Powerful Graphing software has advanced charting features, such as amps vs volts
- Internet Updatable firmware - as we add new features or (heaven forbid) have a firmware bug, the update is just a download away! No need to ship hardware back and forth.
- Full support for English and Metric units

Intended Uses

The eLogger was designed for use in Unmanned Radio Controlled models. Using the eLogger for other purposes is not supported. Further, using the eLogger in situations where its use or failure could result in loss of life, bodily injury or property damage is expressly prohibited.

Packing List

Your package should include the following: eLogger (either with integrated connectors or with wire leads), Custom USB Cable, and CD-ROM.

Steps to Follow

Installation and use of the eLogger will be quite easy and enjoyable if you follow these few steps:

1. Read through the manual to understand the important warnings, determine what parameters you want to log, etc.

2. Install the eLogger in your model, as described in the eLogger Installation section below. Pay special attention to the polarity and plug-in location of the sensors, since some of the plugs will fit in more than one location!
3. Install and configure the Windows software as described in the Windows installation section below.
4. **IMPORTANT: Bench and range test your model as described in the “Using the eLogger” section below.**
5. Have fun!

Installation of the eLogger

IMPORTANT: Never let the sensor/USB prongs of the eLogger touch bare battery pack leads, exposed parts of your ESC/BEC, or the motor casing!! Doing so could destroy the eLogger since these items may have high voltage present from your battery pack, and void the warranty.

The below instructions and diagram guide you through the installation of the eLogger.

Connecting the eLogger to Your Model's Power System

WARNING: High Voltages can cause electric shock. Be extremely careful when working with high voltage packs! Work with high voltages at your own risk.

The eLogger is normally connected so that the connectors or leads marked “Batt” are connected to your battery pack, and the connectors or leads marked “ESC” are connected to your ESC's power input. The red wires of the “wire lead” version of the eLogger must be connected to the **positive** side of the load and source (normally the red wires). For measuring current/voltage battery charging, it is ok to reverse the Batt and ESC connections, so that current is flowing “backwards” through the eLogger. The eLogger will still measure current correctly in this mode!

IMPORTANT: Do not leave your model's power system connected to the eLogger when the unit is not in use in the field. Always disconnect the battery from your model when it is in storage.

IMPORTANT: With the Integrated Connector version of the eLogger, always ensure that the wiper prongs of all plugs are not bent or damaged before connecting! A bent or damaged wiper prong could potentially collapse or fold over during connection, and contact the other terminal of the connection, causing a short, or could result in an unreliable connection.

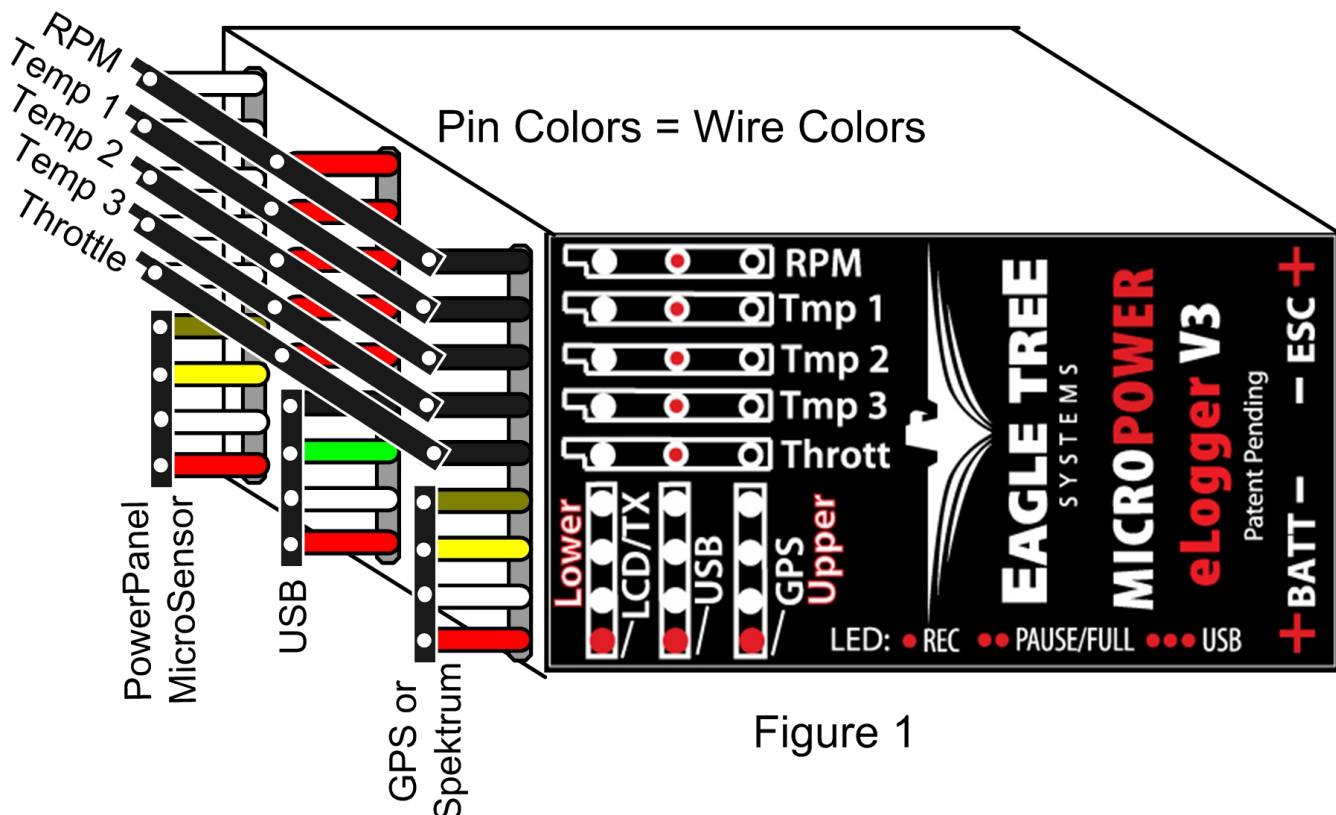

Figure 1

Measuring Temperature with the eLogger

Up to three optional temperature sensors can be connected to the eLogger.

The temperature sensors are typically installed by placing the wire loop around the your battery pack, ESC, BEC, or other location, and cinching it in place by pulling the two rubber stays snugly against the surface to be measured. Or, if you have the Micro temp sensor, it can be slid under heat shrink, taped on, or otherwise affixed.

Plug the Futaba style connector of each temperature sensor into the eLogger as shown in Figure 1.

Note: the Temperature Sensor lead can be easily extended with a standard servo extension cable.

Measuring RPM with the eLogger, Using the Hall RPM Sensor with Magnets

NOTE: see the Brushless or Optical RPM Sensor instruction manuals if you are using one of those sensors.

Installing the optional Hall RPM sensor and magnets is the most challenging part of installation, but is relatively easy once a good mounting location is determined. Refer to our website's Flight support page at <http://www.eagletreesystems.com> for pictures of example installations.

To install our magnets, first find a suitable location on your motor or drivetrain to attach either one or two small magnets and RPM sensor. Typically, the prop washer or prop hub are ideal locations for planes, and the car's axle shaft is good for car installation. This will of course vary with the construction of the model. Make sure the magnets are mounted on some structure that doesn't "flop around," as the magnets could hit the sensor in this case. The RPM sensor must be mounted so that it does not move around, and is within 1-2 mm of the two magnets as they spin. On typical plane installations, there's usually a place where the back of the sensor can be glued to a flat surface under or over the hub which has the magnets mounted. The RPM sensor kit includes four magnets. That provides you with up to 3 spares.

Installing Magnets

Once you have determined where to install the magnets, decide whether you will drill a hole so that the magnets will mount flush with the surface, or if you will just glue the magnets to the surface. Though somewhat more difficult and permanent, mounting the magnet flush with the surface is the best long term approach, since the mounting will be much more rugged, and the risk of imbalance due to not mounting the magnets exactly 180 degrees apart is reduced. In fact, if the magnet is mounted flush in another metal material, it is quite possible that no shaft imbalance will occur if you only mount one of the magnets total.

To flush mount the magnets, drill a hole just slightly larger than the diameter of the magnet size you choose, and of the same depth as that magnet. If you decide to surface mount the magnets, thoroughly clean this area and lightly scuff it to improve adhesion. Glue the magnets **with the side marked with a red line facing inward (hidden)**, using epoxy, or other strong, suitable glue. It's important that the red line on the magnets faces away from the sensor once the sensor is installed. The magnets should be glued 180 degrees apart to keep the shaft in balance.

WARNING: make sure that the magnets are glued sufficiently so that they will not detach and create a hazard, and always wear safety glasses when your motor is running! It is also a good idea to put a piece of heatshrink tubing or electrical tape around the magnets, to further secure them.

Using Existing Magnets

Note: if your motor already has magnets mounted for some other purpose, there's a good chance you can use them. Take one of the magnets included with the RPM sensor kit, and put that magnet up against the previously mounted magnet. If the red line of the eLogger magnet faces down so that the sensor can be mounted facing the side of the magnet with no red line, mount the sensor with the printed side toward the magnet. If the side of the magnet with the red line is visible when on top of the previous magnet, the polarity is reversed. This should work correctly if you install our sensor backwards (printed side of sensor away from magnets).

Installing the RPM Sensor

Once the magnets are glued and completely dry, temporarily position the RPM sensor so that **the side of the sensor with printing (or a colored dot) is facing the side of the magnets WITHOUT the red line**. The sensor now needs to be glued so that it is held rigidly into position. Before gluing, put a small spacer (1-2 mm thick) between the sensor and one of the magnets to ensure proper spacing.

If desired, a small piece of brass tubing can be glued or heatshrunk to the back of the sensor to ease mounting and increase stability.

After the sensor is glued and completely dry, remove the small spacer and rotate the drive train or propeller to ensure complete freedom of movement. Also make sure that the sensor won't vibrate and come in contact with the magnets during operation. If this happens, the sensor will be destroyed, and the eLogger could be damaged.

Once these steps are complete, plug the Futaba style connector on the sensor into the eLogger as shown in figure 1. Note that a standard Futaba style servo extension cable can be used to lengthen the RPM sensor wire if needed.

Using Existing RPM Sensors

Several of our customers have been able to use existing RPM sensors, such as governors or turbine sensors, with our products. The following steps must be followed:

- 1) Determine the "pinout" of the existing sensor. Compatible sensors will have Power, Ground, and Signal connections. The eLogger's RPM pinout, from left to right, is: Power (black wire), Ground (red wire), Signal (white wire).
- 2) Devise a "Y" cable to connect your existing sensor to it's connection, and also to the eLogger's RPM connection. NOTE: Power for the sensor should come only from the connection the sensor is normally plugged into. So, only Ground and Signal wires should be routed from the existing sensor to the eLogger. The power wire of the Y cable between the sensor and the eLogger should be cut before connecting it to the eLogger. This is necessary to avoid connecting the power of the existing sensor connection to the eLogger's power connection.
- 3) Thoroughly test the system to make sure the sensor still works with whatever it was originally connected to, after Y'ing to the eLogger.

Installing a Secondary RPM Sensor

A second MODIFIED Brushless RPM sensor can be plugged into the eLogger's THROTTLE input, for measuring RPM of multiple motors.

NOTE: the Optical and Hall Effects RPM sensors CANNOT be used as secondary sensors, and will be damaged if plugged into any port other than the RPM port. Only the brushless RPM sensor can be used for secondary RPM.

To measure secondary RPM, the RPM sensor must be modified as follows:

- Carefully pry back the plastic tabs that hold the RED and BLACK pins in the RPM sensor connector, and remove the red and black pins.
- Replace the red pin where the black pin was, so that the pin order in the connector is RED, OPEN, WHITE.
- The second RPM sensor plugs into the throttle port with the red wire toward the label side of the logger.
- The black pin (left detached from the connector above) connects to the upper "Tmp 3" pin, nearest the label.

NOTE: The second RPM channel is automatically set up with the same sensor type and gear ratio as the primary RPM. So, it's important that the same type of sensor be used for primary and secondary RPM.

The secondary RPM sensor(s) are logged and displayed on the screens with the other parameters, as described below.

Monitoring your Model's Throttle Position with the eLogger

Connecting the Throttle Servo Y-Cable to your Throttle, and to the eLogger

IMPORTANT: Make sure you connect the battery pack to the eLogger only AFTER connecting the throttle Y cable to the eLogger (and all other connections). The eLogger logs servo positions by measuring the pulses coming from your receiver to the throttle servo, via the optional Y cable. The Y Cable has 3 connections. The "Futaba" male plug (at the "base of the Y") connects to the eLogger as shown in Figure. The universal male and female plugs of the Y cable connect to your receiver's throttle channel, and to your throttle servo,

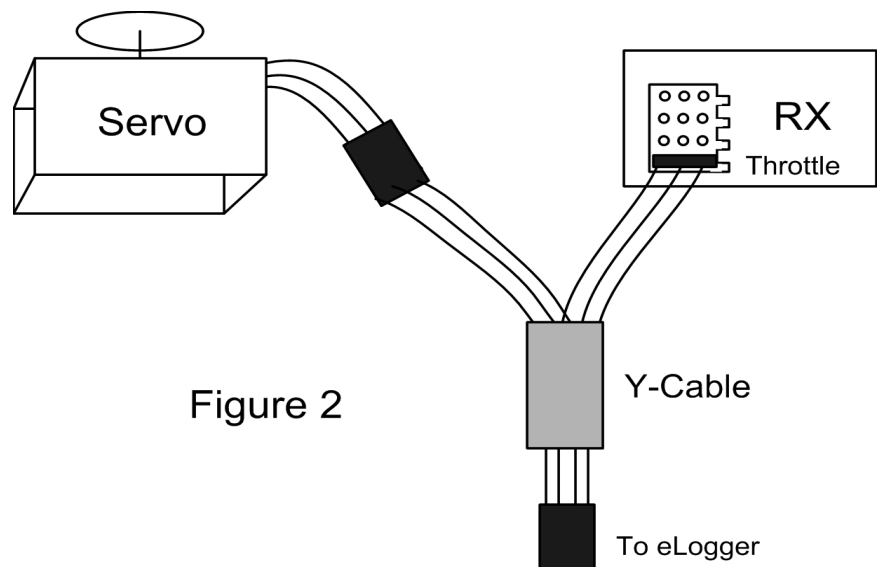

Figure 2

respectively. See Figure 2 for connections of the Y cable to your Receiver and Servo.

Note that when the Y cable is connected to your receiver, there is a common ground connection produced between your receiver and your battery pack, which is also connected to the eLogger. This will bypass any optical or other isolation that might be built into the ground connections of your ESC. We are aware of no issues with connecting a wire between battery ground and receiver ground in these cases, but proceed with caution (at your own risk) as there is the unlikely possibility that your hardware may be damaged by such a connection, and make sure you do an antenna down range check after making this change.

Installing and Using the Windows™ Application

Installing the Windows Application

The supplied Windows application is compatible with USB equipped PCs running Vista, XP, Windows 98SE, Millennium, or Win 2K. The application is not compatible with Windows 98 Original Edition (Gold), or NT 4, even if the PC has USB support.

NOTE: the application included on CD with the unit was current at the time of manufacture. Please check our eLogger Support page on <http://eagletreesystems.com> to see if there is a newer version of the Windows application which may have addressed issues you could encounter.

To install the application, just place the CD in the CD-ROM drive. If AutoPlay is enabled on your PC, the setup program should run automatically. If it does not run, click on My Computer, click on the icon for your CD-ROM drive, and click on the “setup.exe” application icon in the drive window.

Follow the Setup Wizard to install the eLogger application. Once installation is complete, the eLogger may be launched either from its Desktop Icon, or by choosing the eLogger application from the *Start->Programs->Eagle Tree Systems* folder.

Setting up the eLogger with the Application

Once the application is installed, follow the above steps to launch it. The first time the application is launched, the New Model Wizard will be invoked.

The Wizard will prompt you to install the eLogger using the supplied USB cable.

IMPORTANT: Make sure you connect the custom USB plug with the correct polarity, and into the correct connector on the eLogger, as shown in Figure 1.

When you do this for the first time, the behavior will be different depending on which version of Windows you are using:

Windows 98™: The eLogger and application are **not** compatible with Windows 98.

Windows 98SE™ and Windows Millennium™: When the eLogger is first connected to the USB port, the New Hardware Wizard will likely appear. Follow the steps in the Wizard, choosing the options to allow Windows to find the appropriate drivers for the eLogger – these drivers are built into Windows. If the devices you already have on your computer haven’t required the installation of the USB drivers, Windows will prompt you for your Windows CD to copy over the drivers. Once this process is complete, you may be asked to reboot the system. Reboot at this point, then relaunch the eLogger Application, and the New Model Wizard should start up again.

Windows Vista™, Windows 2000™ and Windows XP™: When the eLogger is first connected to the USB port, Windows should automatically install the correct drivers without prompting you. If you should receive a Windows prompt, however, do what it says.

Once the eLogger is correctly discovered and installed by Windows, continue on with the New Model Wizard, relaunching the Windows application after reboot if necessary.

Telling the eLogger what to Log

The first time you run the app, you will be prompted to choose what parameters you wish the eLogger to record. The more items you log, the less record time will be available. A description of the parameters is below:

Electric Motor Voltage: If this option is selected, Pack Voltage is logged.

Electric Motor Current: If this option is selected, Pack Current is logged.

RPM Sensor A: If this option is selected, the eLogger logs the RPM of your model, if you have installed the optional RPM sensor.

Temperature 1: Choose this option if you want to record temperature from an optional temperature sensor.

Temperature 2: Choose this option if you want to record temperature from a secondary optional temperature sensor.

Temperature 3: Choose this option if you want to record temperature from a third optional temperature sensor.

Throttle Movement: Choose this option if you want to record signals from the optional throttle servo Y cable.

Airspeed: Choose this option if you want to record airspeed with the optional Airspeed MicroSensor.

Altitude: Choose this option if you want to record altitude with the optional Altitude MicroSensor.

Servo Current: Choose this option if you want to record servo current with the optional Servo Current MicroSensor.

All GPS Parameters: Choose this option if you want to record GPS Parameters with the optional GPS Expander.

Spektrum™ AR9000™ Flight Log Interface: Choose this option if you want to record AR9000™ or JR 921™ receiver performance data, with the optional Spektrum™ cable.

Setting the “Stop on Full” Feature

After you complete the New Model Wizard for the first time, you will be prompted to choose whether you want the eLogger to write over its data when its buffer becomes full, or to stop when the eLogger is full. NOTE: You can change this setting later from the Hardware menu of the Windows application. If you select “Stop on Full” the eLogger’s LED will flash two flashes in a row when the buffer is full.

Setting the “Set Capture Rate” Feature

The eLogger can be adjusted to capture data in during the recording session at five different rates. The faster the capture rate, the more data is obtained, but at the expense of record time. The default rate, ten samples/second, gives the best resolution, but the record times will be lower than with lower sample rates. You may find that you can get plenty of record time even with the highest capture rate setting, however.

Note: You can change this setting later from the Hardware menu of the Windows application.

A note on record time: The eLogger uses advanced data compression to get the most data recorded as possible. When your model is sitting idle before or after the session with the battery turned on, the eLogger is still capturing data, but since not much is changing very little data is recorded. But when the model is active more data is being recorded.

Setting the “Choose What to Display on the PC Screen” Feature

The eLogger Application can display several model parameters in both numeric and instrument format. Select the parameters you wish the Application to display with this dialog box. Note that some of the parameters require optional accessories, available from Eagle Tree Systems.

Note: Select the “Metric” checkbox on this dialog if you want metric operation.

Also, you can change these settings later from the Software menu of the Windows application.

Configuring and Calibrating the Throttle Function of the Expander with the Windows Application

Calibrating Throttle Movement

It is not absolutely necessary to calibrate the throttle function. The advantages of calibration are that the throttle gauge and graphs will range from zero (closed throttle) to approximately 210 (maximum throttle), as you move your throttle between its extremes. If you do not calibrate, the throttle gauge and graphs will still show throttle movement, but the graph could be inverted if you have the throttle servo reversed, and will not go from zero to 210.

To calibrate the throttle with your model, first connect the throttle Y cable as described above, and connect the eLogger to your PC via the USB cable. Then, click “Calibration, Calibrate Throttle.” The Calibrate Throttle Wizard will then explain the calibration procedure.

Using the eLogger

Once the eLogger and application is installed, it’s almost time to operate! **Please read the important information below on eLogger operation before using it at the field in your model.**

It is extremely unlikely that the eLogger unit will affect your model’s radio range. But, as always after making an electronics change to your model, it is very important that you range and function test your model once the eLogger is installed to ensure that there is no impact on your system. Make sure that your “antenna down” operating range is within the manufacturer’s specifications. See your Radio owner’s manual for the correct procedure for your equipment. **DO NOT OPERATE IF YOUR MODEL DOESN’T PASS THE ANTENNA DOWN RANGE CHECK.**

Additionally, you need to make sure that your Model’s power system is working correctly after adding any new hardware in-line, like the eLogger. This is especially critical in high amperage/voltage installations, of course. It’s important that you safely run your model in an extended stationary “bench” test, similar in duration and power usage to your most aggressive modeling, to ensure there are no problems with any connections, etc. **DO NOT OPERATE YOUR MODEL IF YOU HAVE PROBLEMS DURING THIS EXTENDED STATIONARY TEST!**

The eLogger’s LED

The eLogger’s LED indicates the device’s status.

Once the eLogger is powered up in your model, it will repeatedly flash a sequence of one, two or three flashes every second or so. This flash rate is longer or shorter depending on the capture rate. This flashing indicates the following:

One Flash - The eLogger is actively recording. This is the normal power-up state.

Two Flashes – The eLogger’s buffer is full, or you have enabled logging triggers and the logger is not yet triggered. Note that the eLogger will pause when the buffer is full only if you have selected the “stop on full” mode described above, when the memory is filled to capacity with data.

Three Flashes – The eLogger is connected to your PC’s USB connector, and has been recognized by the PC.

After Your Recording Session

After operating your model with the eLogger, you can either remove the eLogger from your model and take it to your PC, bring the model with the eLogger still in it to your PC, or (if you’re lucky) use a Laptop and connect to the eLogger in the field.

After you connect the eLogger to your PC’s USB interface, the LED should indicate USB connectivity with three repeating flashes as described above.

Once the eLogger is connected, launch the Application and click on the “Download” button. This will load the eLogger’s Data Buffer into the Application for playback and saving.

Use the play controls to play back the data. Note that the Slider can be dragged with the mouse by clicking and holding it then moving it to the desired position.

The application displays the following information:

- **Notifications** – this window displays messages about the recording. The three most common messages are:

- Startup/Reset Detected – this indicates that the eLogger has been turned on at the time specified
- eLogger low battery restart – this indicates that the eLogger has ‘rebooted’ because the power momentarily dropped below around 4.5 volts. See the troubleshooting section if you frequently see this message.
- **Length/Progress** – when stopped, this readout indicates the total recording length. When playing back, this meter indicates current time into the session.
- **Graphical and/or Numeric Pack Voltage** – The application displays the current or max (when playback is stopped) pack voltage readings in either gauge or numeric format.
- **Graphical and/or Numeric Pack Current** – The application displays the current or max pack amperage readings in either gauge or numeric format.
- **Pack Wattage** – this gauge indicates the pack wattage during playback.
- **Cumulative Amp-Hours** – this numeric display indicates the cumulative AH used
- **Graphical and/or Numeric Temperatures** – The application can display up to two Temperature readings in either gauge or numeric format.
- **Graphical and/or Numeric RPM** – The application displays RPM readings in either gauge or numeric format.
- **Graphical and/or Numeric Speed(Cars Only)** – The model’s speed, as computed from the RPM, can be displayed graphically and numerically.

Multiple Session Support

Depending on the length of your modeling sessions, it is often possible to record multiple runs into the eLogger without having to clear the buffer or overwrite data. The eLogger application will split multiple sessions automatically for you. By clicking the “Sessions” option in either the playback or graphing pages of the app, you can display a separate session, or all sessions simultaneously. When graphing all sessions simultaneously, vertical gray bars on the graph indicate where sessions start.

Note that a new session is created in the logger each time it is powered off and on.

Saving eLogger Log Files

After downloading session data, if you wish to save the data to play back later or to share with friends, save the file with the File->Save Recorder File menu. Note that the file is saved with a .FDR extension by default.

USB Live Mode Bench Testing

When the eLogger is installed in your power system, and is also connected to your PC via the USB cable, clicking the Live Mode button in the Windows application will cause the numeric displays and gauges to display data live. Live Mode sessions can be recorded on the PC. To set up Live Mode recording, click “Software, Set Live Mode Options.” If Live Mode recording is enabled, you will be prompted to save the recorded data when you stop live mode by clicking “Stop.”

Also, note that real time strip charting is also supported in Live Mode. To see real time strip charts, first turn on Live Mode recording. Then, click “Graph Data” to launch the graph. Configure the parameters you want to see on the chart, and then click the Live Mode button. Live data will be graphed on the chart!

Graphing/Spreadsheet Compatibility

The eLogger application has extensive graphing capability built in. Just click on “Graph Data!” on the toolbar to graph loaded data. Click on the HELP button on the graphing page for more information on graphing.

Also, the eLogger’s Data File is compatible with Excel™ spreadsheet software, and perhaps other spreadsheet brands. Using Excel™ is useful for graphing the data output from the eLogger.

To load in Excel, save the data file from “File->Save Recorder File,” and in Excel™ choose File->Open, and select “All Files” in the “Files of Type” box. Navigate the Excel dialog box to the location you saved the .FDR data file, and click on the filename. Excel should then bring up the “Text Import Wizard”. Choose the “Delimited” option, and on the next page choose “Delimited with Spaces”. The data should then load correctly in Excel.

The format of each line of data in the file is:

First Line: Model Name

Second Line: Data about your Model’s setup. This line is needed to allow sharing of your session log files with others.

Third line: header indicating what each of the data fields represents. These columns are:

GPSSpeed	GPSCourse	GPSDist	GPSUTC	NumSats	GPSFlags				
Milliseconds	IsEvent	EventError	EventData	Altitude	Airspeed	ServoCurrent*100	Throttle	PackVolt*100	
Amps*100	Temp1*10	Temp2*10	Temp3*10	RPM	RPM2	GPSLat	GPSLon	GPSAlt	

If “IsEvent” is 1, the record contains event data as well as regular data. Typical events are power-up (restart), and servo glitches. Ignore the non-event fields when IsEvent is set to 1.

Event Codes in the “EventCode” field are as follows. Note that codes other than those below should be reported to Eagle Tree Systems:

```
9 = ERROR_RESTART: The eLogger has been started or restarted (power was applied)
18 = ERROR_GPS_DATA_PACKET: GPS Data was received from the GPS Expander,
27 = ERROR_SPEKTRUM_DATA_PACKET: Data was received from the AR9000 Interface
```

Milliseconds indicates when each record was collected, in Milliseconds since the eLogger was turned on. Email us if you need more information on the file format.

Happy Modeling!!

Troubleshooting

Below is a list of problems that may be encountered, and steps to remedy them.

A good first step to troubleshooting, if you are able to connect your eLogger to your PC, is to download our latest software and update the eLogger’s Firmware via “Hardware, Firmware Control.” Doing this will ensure that you have the latest software and firmware available.

If your particular issue is not addressed by this update, or by the suggestions below, please visit our web support page for additional support options, at <http://www.eagletreesystems.com/Support/support.html>.

Issue: My PC does not recognize the eLogger.

Solution: Try to eliminate the problem in the following ways:

- Disconnect all other USB peripherals from your PC (if possible) and try the eLogger again.
- Try the eLogger on a different PC. If it works, there may be a misconfiguration with your PC.
- Try the eLogger with a different USB cable, if you have one. If this works, your cable has been damaged.
- Try rebooting your PC – occasionally USB support gets disabled with some PCs.
- Try the other USB connector on your PC if it has two.
- Ensure that USB is enabled within your Operating System by checking in Device Manager. You’ll need to see your Windows™ documentation to determine how to do this on your particular OS version.

Issue: RPM is not working correctly (note: also see the Optical or Brushless RPM Sensor instruction manual if you are using the Optical or Brushless RPM Sensor)

Solutions:

- With the magnetic sensor, check to make sure your sensor to magnet gap is around 2mm or less.
- Check the magnet polarity mounting. The magnet should have been glued so that the red line faces down, away from the sensor, and the writing on the sensor faces the magnet. If you inadvertently glued the magnet so that the red line is facing UP, flip the sensor over so the "non printed" side faces the magnet.
- Make sure that under Choose What to Log in the app, you have checked RPM.
- Make sure that the RPM sensor is plugged into the correct slot on the eLogger
- Connect the eLogger to the computer and launch the Windows Application. Then, click the “Live Mode” button. Make sure that the RPM gauge is displayed, and spin the magnets, or wave the magnets by hand in front of the sensor. Try both sides of the magnets and both sides of the sensor. See if the RPM reading jumps.

Issue: I have a fully charged battery, but the eLogger frequently shows “Low Battery Restart” Notifications when playing back data.

Solution: The eLogger shuts down immediately if the power goes below around 5 volts for more than a few milliseconds, and logs this occurrence when the power returns to above 5 volts. If your battery’s voltage frequently drops this low, you may be underpowered, and may want to consider getting a bigger battery.

Issue: the Current or Voltage being logged by the eLogger appears incorrect.

Solutions:

- Make sure that the parameters you wish to log are checked under “Hardware, Choose Parameters to be logged in Recorder”
- If the current being logged by the eLogger appears to be incorrect, connect a battery pack to the eLogger, and connect the eLogger to USB. Then, click “Calibration, Rezero Current Sensors” to rezero your sensor. Make sure that no ESC or other load is connected to the eLogger during this step! Note that this calibration step is done at the factory before shipping, but it may be possible for drift to occur after the eLogger has been in operation for some time.

- If the current readings appear to be inaccurate even after you have completed the “Calibration, Rezero Current Sensors” step above, or if voltage readings appear to be slightly different than another meter you are accustomed to, it is easy to calibrate the eLogger readings to your other meter’s readings if desired. This is done by choosing “Advanced, Calibrate Pack Voltage and Amperage” and entering the values your meter reads, and the eLogger reads. If you don’t desire to change the calibration on, say, voltage, but wish to change it for amperage, just leave the voltage fields as 0, and the calibration for voltage will not change. The eLogger is factory calibrated using a highly accurate current and voltage measurement tool.
- If the eLogger appears to be reading highly inaccurate voltages or currents, the first thing to try is to clear all calibration. This is done running the calibration tool as described above, but entering the same values for the problem measurement. For example, if amperage is way off, enter the same value (say, 5.0) for both the eLogger amperage and the “my other meter” amperage, which will clear all internal and user calibration.

Issue: the temperature appears to be logged incorrectly.

Solutions:

- Make sure that the parameters you wish to log are checked under “Hardware, Choose Parameters to be logged in Recorder”

Issue: Throttle Movements are not correct, or the throttle cannot be calibrated.

Solutions:

- Ensure you have connected the Y cable as shown in Figure 1.
- Complete the Throttle Calibration step as described above.
- Make sure you are logging throttle movements in the eLogger.

Issue: The eLogger shuts off or the LED flashes rapidly when used with the GPS Expander.

Solutions:

- The GPS Expander draws significant current from the eLogger. When the eLogger is powered by a higher voltage pack, such as an 8s or larger pack, or a pack above 30 volts, the eLogger’s regulator may shut off after a short period when used with the GPS. Please use our “Battery Backup Harness”, part number CAB-BAT-BACK, to provide supplemental power to the eLogger, if you encounter this issue.

eLogger Specifications

Voltage Measurement: approx 5V to 70V

Voltage Resolution: approx 0.02V

Current Measurement: up to 100 Amps, (150 Amps with the MPRV3-LEADS-150)

Current Resolution: approx 0.02 Amps (0.035 Amps with the MPRV3-LEADS-150)

Current Draw: approx 30 mA with no sensors

Weight: Unit with Integrated Connectors: approx 0.7oz (20 grams), 100 amp unit with Wire Leads: 0.9 oz (25 grams)

Temperature: Dual inputs, 0 degrees F to 424 degrees F (three temperature inputs)

RPM range: approx 100 RPM to 50,000+ RPM

Units of Measure supported: English and Metric

Measurements: approx 2.25” x 1” x 0.5” (57mm x 28mm x 13mm) including sensor pins

Length of Wires with Wire Lead Version: approx 2.5” (65mm)

Record Time: Varies with sample rate, parameters being recorded, and “activeness” of the model. Anywhere from around 45 minutes to many hours is attainable depending on these settings.

Limited Warranty

Eagle Tree Systems, LLC, warrants the eLogger to be free from defects in materials and workmanship for a period of one (1) year from the date of original purchase. This warranty is nontransferable. If your unit requires warranty service during this period, we will replace or repair it at our option. Shipping cost to us is your responsibility.

To obtain warranty service, contact us by phone, fax or email to request an RMA number. No returns will be accepted without this number.

This limited warranty does not cover:

- The Software included with the eLogger. See the Software license agreement for more information on Software restrictions.
- Problems that result from:
 - External causes such as accident, abuse, misuse, or problems with electrical power
 - Servicing not authorized by us
 - Usage that is not in accordance with product instructions

- Failure to follow the product instructions

THIS WARRANTY GIVES YOU SPECIFIC LEGAL RIGHTS, AND YOU MAY ALSO HAVE OTHER RIGHTS WHICH VARY FROM STATE TO STATE (OR JURISDICTION TO JURISDICTION). OUR RESPONSIBILITY FOR MALFUNCTIONS AND DEFECTS IN HARDWARE IS LIMITED TO REPAIR AND REPLACEMENT AS SET FORTH IN THIS WARRANTY STATEMENT. ALL EXPRESS AND IMPLIED WARRANTIES FOR THE PRODUCT, INCLUDING, BUT NOT LIMITED TO, ANY IMPLIED WARRANTIES AND CONDITIONS OF MERCHANTABILITY AND FITNESS FOR A PARTICULAR PURPOSE, ARE LIMITED IN TIME TO THE TERM OF THE LIMITED WARRANTY PERIOD AS DESCRIBED ABOVE. NO WARRANTIES, WHETHER EXPRESS OR IMPLIED, WILL APPLY AFTER THE LIMITED WARRANTY PERIOD HAS EXPIRED. SOME STATES DO NOT ALLOW LIMITATIONS ON HOW LONG AN IMPLIED WARRANTY LASTS, SO THIS LIMITATION MAY NOT APPLY TO YOU.

WE DO NOT ACCEPT LIABILITY BEYOND THE REMEDIES PROVIDED FOR IN THIS LIMITED WARRANTY OR FOR CONSEQUENTIAL OR INCIDENTAL DAMAGES, INCLUDING, WITHOUT LIMITATION, ANY LIABILITY FOR THIRD-PARTY CLAIMS AGAINST YOU FOR DAMAGES, FOR PRODUCTS NOT BEING AVAILABLE FOR USE, OR FOR LOST DATA OR LOST SOFTWARE. OUR LIABILITY WILL BE NO MORE THAN THE AMOUNT YOU PAID FOR THE PRODUCT THAT IS THE SUBJECT OF A CLAIM. THIS IS THE MAXIMUM AMOUNT FOR WHICH WE ARE RESPONSIBLE.

SOME STATES DO NOT ALLOW THE EXCLUSION OR LIMITATION OF INCIDENTAL OR CONSEQUENTIAL DAMAGES, SO THE ABOVE LIMITATION OR EXCLUSION MAY NOT APPLY TO YOU.

Product Warranty Registration

Registering your product means that we can send you important updates and other notifications. Please fill out this form (or a copy) and mail or fax it to Eagle Tree Systems. Or, email the info to sales@eagletreesystems.com. Note that if you purchased your item directly from Eagle Tree Systems, this is not necessary.

Eagle Tree Systems Warranty Product Registration:	
Name:	_____
Address:	_____
Phone:	_____ Email: _____
Product(s) Purchased:	_____ Date Purchased: _____
Where did you purchase your product?	_____
Where did you hear about our product?	_____
Any features or additions you would like to see?	_____